

# E6 ELLIPTICAL

**SKU: CT-E6**



Large cup & accessories holder



Intuitive, LED console with reading rack/tablet holder



Heavy-duty steel frame with 20" natural stride



## STANDARD FEATURES

- Cordless - self-powered.
- Ergonomic, over-sized footplates.
- Easy to use touchpad with quick resistance shifter.
- Contact and telemetric heart-rate sensors.
- Convenient reading rack/tablet holder.
- Low step-up height.
- 20" natural stride.
- Zinc-dipped anti-corrosion coating for superior rust protection.
- Full commercial components on a durable commercial frame.

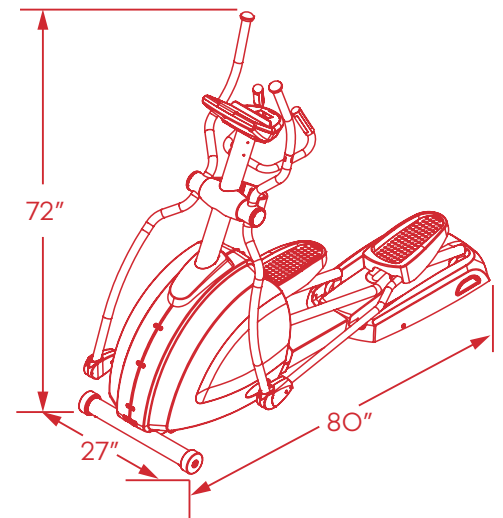



**TECHNICAL AND CONSOLE SPECIFICATIONS**

<b>TECHNICAL SPECIFICATIONS</b>	STRIDE LENGTH	20" (500mm)
	PEDAL SPACING	2.5" (64mm)
	STEP UP HEIGHT	12" (320mm)
	RESISTANCE LEVEL	16 levels
	MAXIMUM USER WEIGHT	400 lbs (181 kgs)
<b>ELECTRICAL SPECIFICATIONS</b>	POWER REQUIREMENT	Self Generation
	MAXIMUM WATT @ 60 RPM	250W
	MINIMUM WATT @ 60 RPM	20W
	MINIMUM RPM	30 RPM
<b>FRAME</b>	FRAME MATERIAL	Zinc-dipped, powder-coated steel frame
	COLOR OPTIONS	Jet Black
	NET WEIGHT OF FRAME & CONSOLE	224.4 lbs (102 kgs)
	PACKAGED WEIGHT	249.7 lbs (113.5 kgs)
<b>DIMENSIONS</b>	EQUIPMENT DIMENSIONS	80 (L) X 27 (W) X 72 (H) in / 2040 (L) X 680 (W) X 1810 (H) mm
	PACKAGING DIMENSIONS	83 (L) X 28 (W) X 30 (H) in / 2120 (L) X 700 (W) X 770 (H) mm
<b>DISPLAY AND CONNECTIVITY</b>	SCREEN	8x16 Dot-Matrix w/ Message Window + HR Status Bar
	LANGUAGE OPTIONS	English
	PRE-PROGRAMMABLE WORK OUTS	Yes, 10
	QUICK START OPTIONS	Yes
	CSAFE	Optional
	HEART RATE (HR) DETECTION	Hand Pulse (5kHz Wireless)