

HOIST
FITNESS



CLUB LINE

CL

THE SLIDE SELECT SYSTEM

The most talked about feature of the Club Line, the **Slide Select System**, eliminates guide rods and selector pins, requires less maintenance, and has a smoother function than a traditional selectorized machine. It also features a built-in smaller weight adjustment in five pound increments on the two hundred and three hundred pound systems. Finally, with no clanging weights, the Slide Select System is much quieter than the traditional weight stack resistance system.





CLUB LINE

WHAT'S UNIQUE ABOUT THE CLUB LINE?

- 16% smaller footprint
- 19% lower profile
- Quiet operation
- No loose pins or lanyards
- Smooth feeling movements
- Sleek design
- More increments
- Simple weight selection
- CL-3102 Preacher Curl 200 lb
- CL-3103 Triceps Press 200 lb
- CL-3201 Lat Pulldown 300 lb
- CL-3203 Mid Row 300 lb - **New**
- CL-3301 Chest Press 300 lb
- CL-3309 Pec Fly / Rear Delt 200 lb - **New**
- CL-3401 Leg Extension 300 lb
- CL-3402 Leg Curl 300 lb
- CL-3403 Leg Press 300 lb (*400 lb option available)
- CL-3408 Standing / Prone Leg Curl 300 lb - **New**
- CL-3501 Shoulder Press 200 lb
- CL-3502 Lateral Raise 200 lb - **New**
- CL-3601 Abdominals 300 lb - **New**
- CL-3800 Inner / Outer Thigh 200 lb - **New**

The new CLUB LINE from HOIST Fitness offers a smaller, quieter option to owners looking for more space in their facility with the premium equipment that only HOIST Fitness can offer.

Compared to six major competitors, the original 8 CLUB LINE units take up 8-25% less floor space per machine, leaving more room for facilities to utilize. Competitors also have machine profiles that are 8-27% taller, significantly obstructing and cluttering views.

Each unit has a convenient accessory tray for keys, a phone, and water bottle as well as easy weight selection from a seated position.

"The Club Line has a very naturally smooth and consistent feel across the line. And I like the dampening feeling after completing a rep with no crashing weight stacks. Also, the Slide Select System is completely unique and easy to use"

-Anthony Wall with the American Council on Exercise (ACE)

PREACHER CURL

CL-3102



FEATURES:

- Oversized, wrap around arm pad with ergonomically optimized 40 degree angle
- Independent exercise arms with rotating grips
- Gas-spring assisted seat adjuster with easy-to-reach handle
- 200 lb weight stack

TRICEPS PRESS CL-3103



FEATURES:

- Oversized, wrap around arm pad with ergonomically optimized 40 degree angle
- Easy to adjust counter balanced arm
- Stabilizing bar to lock feet underneath while exercising
- Gas-spring assisted seat adjuster with large easy-to-reach handle
- 200 lb weight stack

LAT PULLDOWN CL-3201



FEATURES:

- Independent handles with multiple grips including rock climbing grips and HOIST's unique Flip 'N Grip® handles
- Oversized seat fits wide range of users
- Counter-balanced arm
- Gas-spring assisted seat adjuster with large easy-to-reach handle
- 300 lb weight stack

MID ROW CL-3203



FEATURES:

- Select-A-Grip handles provide the options for vertical, angled, and horizontal grips
- Oversized seat fits wide range of users
- Gas-spring assisted seat adjuster with large easy-to-reach handle
- 300 lb weight stack

CHEST PRESS
CL-3301



FEATURES:

- Multiple grip options
- Foot assist to help get into a starting position and complete those final reps
- Gas-spring assisted seat adjuster with large easy-to-reach handle
- 300 lb weight stack

PEC FLY / REAR DELT CL-3309



FEATURES:

- Multiple grip options
- First machine ever to offer both exercises facing the same direction
- Gas-spring assisted seat adjuster with large easy-to-reach handle
- 200 lb weight stack

LEG EXTENSION CL-3401



FEATURES:

- Self-adjusting roller pad
- Large, easy to control range of motion lever for exercise arm
- Counter-balanced arm for easy adjustments
- Stabilizing handles
- Gas-spring assisted seat back adjustment with easy-to-reach lever
- 300 lb weight stack

LEG CURL CL-3402



FEATURES:

- Self-adjusting roller pad
- Large, easy to control range of motion lever for exercise arm
- Counterbalanced arm with large range of motion lever for easy, controlled adjustments
- Stabilizing handles
- Gas-spring assisted seat back adjustment with easy-to-reach lever
- 300 lb weight stack

LEG PRESS

CL-3403 / CL-3403-HS



FEATURES:

- Unique suspended 4-bar linkage creates one of the smallest leg press footprints and a strength curve with no drop off
- Oversized foot plate with anti-slip rubber surface
- Extra raised foot plates for calf presses
- Entry / exit assist handle
- 300 lb weight stack and 400 lb Heavy Stack (HS) option available

STANDING / PRONE LEG CURL

CL-3408



FEATURES:

- Adjustments allow for standing and prone leg curl variations with ability to do unilateral or bilateral in the laying position
- Self-adjusting roller pad
- Stabilizing grips for both standing and laying variations
- 300 lb weight stack

SHOULDER PRESS CL-3501



FEATURES:

- Multiple grip handles
- Counter-balanced arm
- Gas-spring assisted seat adjuster with large easy-to-reach handle
- 200 lb weight stack

LATERAL RAISE CL-3502



FEATURES:

- Independent exercise arms with rotating grips
- Counter-balanced arm
- Gas-spring assisted seat adjuster with large easy-to-reach handle
- 200 lb weight stack

ABDOMINALS CL-3601



FEATURES:

- Foot stabilizing bar and elbow pads to get proper leverage
- Counter-balanced arm
- Gas-spring assisted seat adjuster with large easy-to-reach handle
- 300 lb weight stack

INNER / OUTER THIGH CL-3800



FEATURES:

- Standing and sitting variation grip handles
- Independent swiveling thigh pads
- Gas-spring assisted seat adjuster with large easy-to-reach handle
- 200 lb weight stack

**16% SMALLER,
19% LOWER PROFILE**

ORIGINAL 8 PIECES OF
THE CLUB LINE FIT IN
THE SPACE OF A
ONE CAR GARAGE

*Diagram is to scale

22 ft

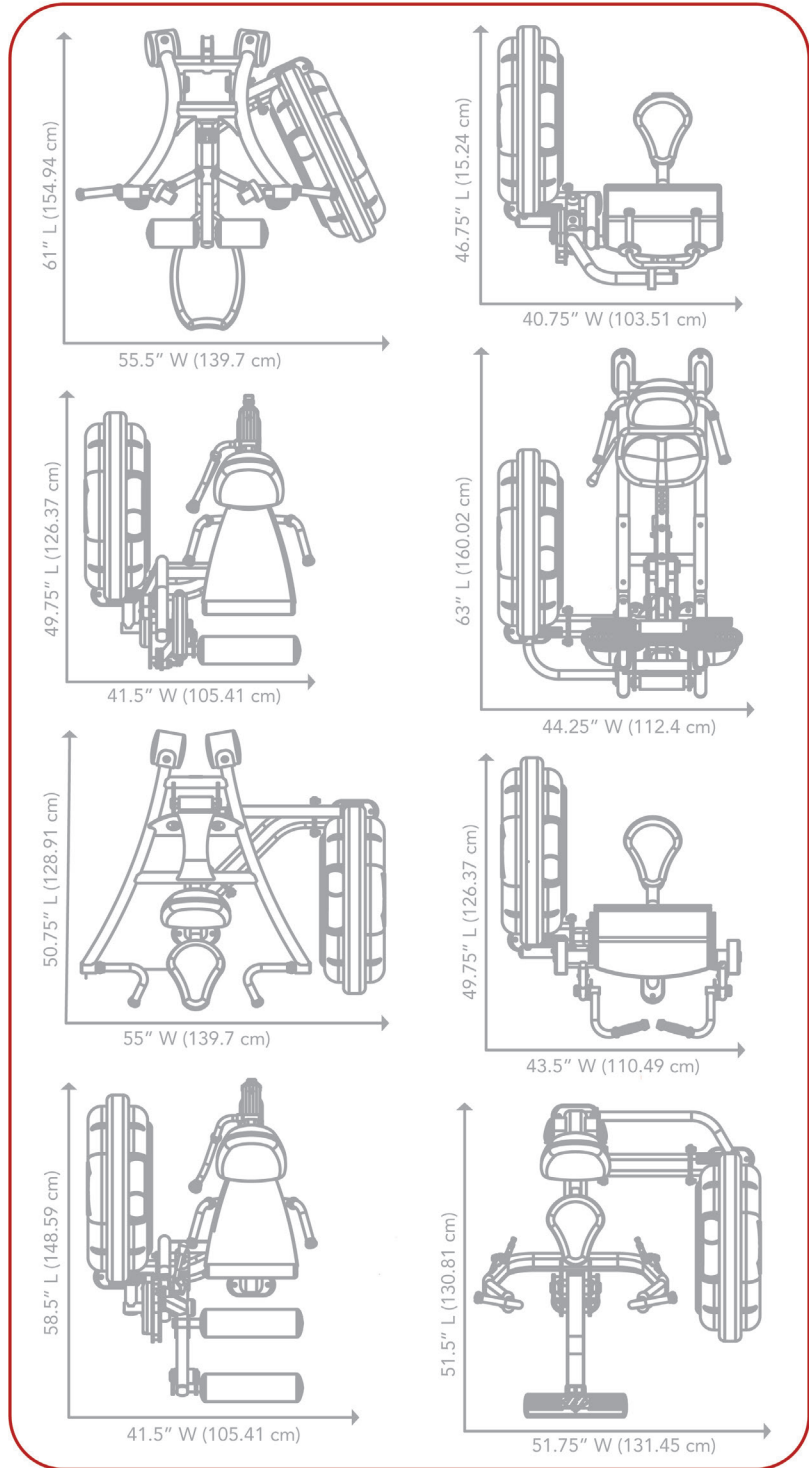

12 ft

HOIST Custom Artwork

Shield Wraps and Logo Decals

HOIST Fitness is pleased to offer custom designed shield wraps for Club Line equipment to brand the units to your facility's unique style. Designed to complement the elegant CL shields, wraps can be customized for the front and back of each piece.

To best assist the designer in creating your custom artwork, please provide frame and upholstery colors for the units being ordered and art direction such as branding guidelines or a website that can be used as a basis for your design. If you would like to have a matching logo decal created with your shield wrap, please specify that when ordering.

ARTWORK SPECIFICATIONS:

Vectorized artwork is the preferred format, be it a logo or graphic, as this can be scaled to any size without loss of quality to the artwork.

Vector Artwork File Types: *.EPS, .PDF, .AI*

All other artwork must be provided at 300 DPI and at the minimum dimensions to fit into the chosen shield size. Active artwork is preferred in order to properly set the artwork to the proper size and angle. Outlined fonts are requested if fonts files are not provided. Editable Artwork File Types: *.PSD, .PDF*



DISCLAIMER PLEASE READ CAREFULLY: Actual frame and upholstery colors may differ from printed color samples and mock-ups shown. These mock-ups should be considered reference only. Due to the printing materials and method used, colors are subject to variation and color matching cannot be guaranteed. To help us match colors as closely as possible, please provide specific CMYK color codes per each color required and be advised that Neon colors are not available.

STANDARD COLORS

----- FRAME -----



----- UPHOLSTERY -----

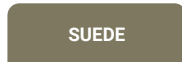

Actual frame and upholstery colors may differ from color samples shown.

PRODUCT NAME		LENGTH	WIDTH	HEIGHT	WEIGHT	WEIGHT STACK
CL-3102	PREACHER CURL	49.75" (126 cm)	43.50" (110 cm)	48.50" (123 cm)	481 lbs (218 kg)	200 lbs (91 kg)
CL-3103	TRICEPS PRESS	47.50" (121 cm)	40.75" (104 cm)	48.50" (123 cm)	502 lbs (228 kg)	200 lbs (91 kg)
CL-3201	LAT PULLDOWN	54.50" (138 cm)	55.50" (141 cm)	81.00" (206 cm)	692 lbs (314 kg)	300 lbs (136 kg)
CL-3203	MID ROW	56.13" (143 cm)	48.38" (123 cm)	48.38" (123 cm)	625 lbs (283 kg)	300 lbs (136 kg)
CL-3301	CHEST PRESS	51.50" (131 cm)	51.75" (131 cm)	50.00" (127 cm)	613 lbs (278 kg)	300 lbs (136 kg)
CL-3309	PEC FLY / REAR DELT	45.25" (115 cm)	66.38" (169 cm)	48.38" (123 cm)	425 lbs (192 kg)	200 lbs (91 kg)
CL-3401	LEG EXTENSION	49.75" (126 cm)	41.50" (105 cm)	48.50" (123 cm)	626 lbs (284 kg)	300 lbs (136 kg)
CL-3402	LEG CURL	58.50" (149 cm)	41.50" (105 cm)	48.50" (123 cm)	629 lbs (285 kg)	300 lbs (136 kg)
CL-3403	LEG PRESS	63.00" (160 cm)	44.25" (112 cm)	48.50" (123 cm)	782 lbs (355 kg)	300 lbs (136 kg)
CL-3408	STANDING / PRONE LEG CURL	53.00" (135 cm)	42.50" (108 cm)	48.38" (123 cm)	550 lbs (249 kg)	300 lbs (136 kg)
CL-3501	SHOULDER PRESS	50.75" (129 cm)	55.00" (140 cm)	50.00" (127 cm)	568 lbs (258 kg)	200 lbs (91 kg)
CL-3502	LATERAL RAISE	42.75" (109 cm)	47.88" (122 cm)	49.13" (125 cm)	550 lbs (249 kg)	200 lbs (91 kg)
CL-3601	ABDOMINALS	41.25" (105 cm)	49.38" (125 cm)	61.38" (156 cm)	650 lbs (294 kg)	300 lbs (136kg)
CL-3800	INNER / OUTER THIGH	62.63" (159 cm)	35.00" (89 cm)	48.38" (123 cm)	700 lbs (317 kg)	200 lbs (91 kg)



WARRANTY POLICY

HOIST® Fitness offers one of the best warranty policies in the industry, reaffirming our commitment to quality and customer satisfaction. HOIST® Fitness warranties this product to the original purchaser only. HOIST® Fitness guarantees this product to be free from defects in workmanship and/or materials under normal use or service. **FOR COMPLETE WARRANTY INFORMATION, VISIT HOISTFITNESS.COM AND CLICK ON THE "SUPPORT" LINK.** Warranty policy applies to defects from the manufacturer only.

HOIST® Fitness reserves the right to change product specifications, design, and function at any time.

TRADEMARKS AND PATENTS

HOIST® Fitness products are covered by U.S. Patents, Patents Pending and Trademarks. HOIST is a registered trademark. All Rights Reserved.†

- HOIST®
- ACT NOW®
- CABLE-DRIVEN™
- CLUB QUALITY GUARANTEED®
- COMPOSITE MOTION™
- DUAL ACTION SMITH®
- EASY GLIDE™
- EZ-LOC LATCHING MECHANISM™
- FEEL THE RIDE®
- GLUTEMASTER®
- HOIST CLASSIC®
- QUIK-CHANGE®
- RADIAL LOC®
- RIDE ORIENTED CIRCUIT-INTERVAL TRAINING™
- RIDE ORIENTED CONDITIONING®
- RIDE ORIENTED CONDITIONING SYSTEM®
- RIDE ORIENTED CONDITIONING-INTENSITY TRAINING™
- RIDE ORIENTED XERCISE®
- ROC®
- ROCS®
- ROX®
- ROC-IT®
- ROC-ABS®
- SILENT STEEL®
- SPLIT WEIGHT CABLING™
- ULTRA-LITE LIFTING SYSTEM™
- DUAL SERIES™

D427,652, D431,059, D431,615, D437,370, D437,371, D438,267, D439,292, D439,822, D439,943, D440,610, D444,190, D444,518, D446,440, D446,831, D454,604, D455,184, D455,310, D455,803, D456,862, D457,580, D511,726, D513,598, D518,861, D519,585, D519,864, D526,370, D528,023, D528,172, D533,608, D536,046, D539,857, D541,357, D541,358, D541,893, D542,868, D544,050, D545,383, D556,842, D561,276, D569,459, D569,926, D574,448, D574,449, D577,234, D578,584, D579,989, D583,426, D590,032, D746,388, D797,757, D807,446, D807,447, D808,475, D818,547, 5,683,334, 5,733,233, 5,800,321, 5,807,219, 5,916,072, 5,951,444, 5,961,428, 5,980,434, 6,004,247, 6,193,635, 6,264,586, 6,319,178, 6,338,701, 6,347,777, 6,409,637, 6,443,878, 6,491,606, 6,491,609, 6,497,639, 6,551,226, 6,561,960, 6,579,213, 6,605,022, 6,988,977, 7,052,444, 7,166,066, 7,316,634, 7,322,906, 7,322,911, 7,331,911, 7,335,140, 7,361,125, 7,384,381, 7,393,309, 7,749,143, 7,468,024, 7,544,156, 7,549,880, 7,549,949, 7,563,209, 7,563,214, 7,594,880, 7,597,655, 7,601,187, 7,641,600, 7,654,938, 7,654,940, 7,670,269, 7,713,179, 7,717,832, 7,731,638, 7,749,371, 7,749,372, 7,766,802, 7,806,809, 7,815,555, 7,867,149, 7,878,953, 7,901,335, 7,901,337, 7,909,743, 7,938,760, 7,963,890, 7,976,440, 7,981,010, 7,988,603, 7,993,251, 8,002,679, 8,007,411, 8,021,070, 8,057,368, 8,162,807, 8,172,732, 8,177,693, 8,257,231, 8,308,620, 8,317,665, 8,328,698, 8,562,496, 8,702,573, 8,734,304, 8,852,060, 8,870,720, 8,915,667, 8,926,480, 9,017,238, 9,126,081, 9,205,298, 9,302,136, 9,440,106, 9,517,379, 9,522,297, 9,604,086, 9,682,276, 9,707,448, 9,808,699, 9,833,656, 9,861,850, 9,868,016, 9,925,448, 9,943,721, 9,950,210, 9,968,819, 9,999,797, 10,010,740

† Other Patents Pending

